



**IMPACT® 2-DUO AND DUO LRN
DISPOSABLE FILTERS**

*Dual functionality disposable filters for advanced
point-of-use photoresist filtration down to 5 nm retention*



disposable filters for advanced point-of-use photoresist filtration

Overview

Developed from the Mykrolis® family of photochemical contamination control technologies, the Impact 2-Duo filter is intended for use in advanced photoresist process (i.e ArF and EUV) chemistries where the highest level of retention, cleanliness and technical support that only Entegris can bring is required. The Impact 2-Duo filter uses a combination of a UPE membrane and a nylon layer to maximize sieving and nonsieving retention capabilities to reduce advanced process defects caused by gels, particles and/or molecular polymers in some advanced chemistries. Duo's innovative design of nylon upstream and UPE downstream ensure the highest level of retention achieved by using either a UPE 5 nm, 10 nm or 30 nm filter while also increasing chemical compatibility due to UPE downstream configuration in the filter.

UHMWPE Membrane: Sieving Retention

Duo's superior sieving retention is accomplished mostly by the UPE membrane used. Sieving retention of 30 nm and below is effective at reducing gels, hard/soft particles and some molecular contaminants that can lead to defects. UPE is widely used in sub 45 nm photoresist manufacturing and advanced point-of-use photochemical filtration. By using 5 nm, 10 nm and 30 nm retention rated

UPE filters, Impact 2-Duo filter provides you with the sieving retention needed to advance to smaller and smaller linewidths while ensuring universal chemical compatibility.

Nylon Layer: Nonsieving Retention and Low Resistance Layer

Duo's nylon layer ensures a high level of nonsieving retention required for specific photoresist chemicals* and other ancillaries used in the lithography process. The nonsieving retention is required in some chemistries to reduce such defects as microbridging and cone that can be caused by molecular or metal contaminants not easily removed by sieving retention alone. Duo's nylon layer has been carefully chosen to ensure optimal chemical compatibility and structure to ensure product lifetime. Our latest technology uses a Low Resistance Nylon media (LRN) that enables filtration down to 5 nm while maintaining a low pressure drop across the filter. This allows for a wider window of operation in a diverse set of dispense systems.

* Dual functionality is not required for all chemistries; please consult your local sales representative or visit www.entegris.com.

Features	Benefits
Dual functionality filter	Dual functionally technology can remove difficult contaminants from specific resists where a single retention technology might not succeed. The combination of the UPE membrane and nylon layer provides the maximum chemical compatibility and lifetime.
5 nm, 10 nm and 30 nm sieving retention	UPE sieving retention ensures you can meet critical line width processes.
Nylon nonsieving retention	Nylon layer provides the nonsieving retention needed in specific chemistries where contaminants can cause defects.
Connectology® technology	Rapid changeout and ease-of-use to maximize equipment uptime. Designed to be used on our patented two-stage technology dispense systems or with an Impact Plus manifold.
Low hold-up volume	Minimizes chemical waste.
Manufactured using our proprietary cleaning technology	Ensures that extractables are not an issue in your advanced lithography process.
Patented Low Resistance Nylon media (LRN)	Reduces pressure drop while maintaining a high level of nonsieving retention.

Specifications

Material:	Sieving membrane	Ultra-high molecular weight polyethylene (UHMPE)
	Nonsieving layers	Nylon 6 (30 nm and 10 nm), Low Resistance Nylon media (5 nm)
	Supports	(Upstream and downstream) PE
	Molding	HDPE
	Manifold/fittings	With Impact 2 manifold (Uses same as Impact 2 manifold for fittings)
Dimensions:	Height	90 mm (3.54")
	Width	71.9 mm (2.83")
	Depth	95.5 mm (3.76")
Maximum operating conditions:	Maximum inlet pressure	0.34 MPa (3.4 bar, 50 PSI) @ 25°C (77°F)
	Maximum forward/reverse differential pressure	0.27 MPa (2.7 bar, 40 PSI) @ 25°C (77°F)
	Maximum operating temperature	40°C (104°F)
Membrane area:	800 cm ² (0.861 ft ²)	5 nm
	850 cm ² (0.915 ft ²)	10 nm, 30 nm
Hold up volume:	≤55 cc	
Compatibility:	PGMEA, PGME, NMP, ethyl lactate, MMP, and cyclohexanone Not recommended for use with photochemicals containing aromatic hydrocarbons	
Wettability:	Spontaneously wets in butyl acetate, PGMEA, PGME, ethyl lactate, MMP, ECA, NMP and other photochemical solvents	

Dimensions

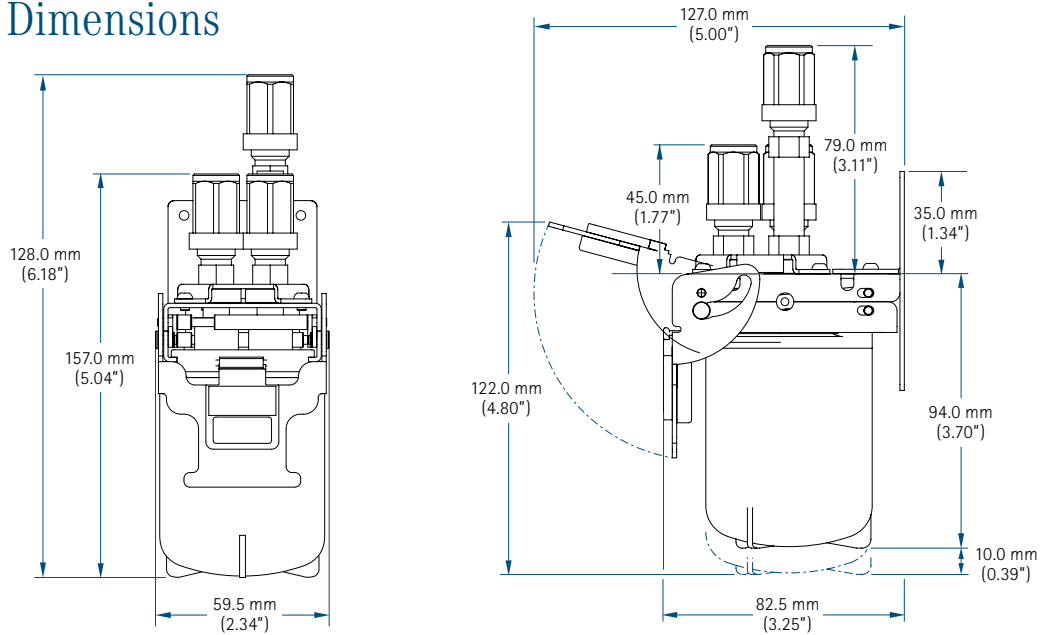

Performance Data

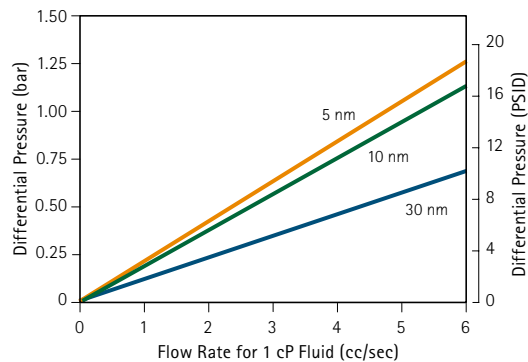

Ordering Information

Part Number	Description
A2D F20 001	Impact 2 Duo LRN 5 nm OM
A2D F20 0K1	Impact 2 Duo LRN 5 nm OF Kalrez®
A2D T20 001	Impact 2-Duo 10 nm OM
A2D Y20 001	Impact 2-Duo 30 nm OM
A2D T20 0K1	Impact 2-Duo 10 nm OF Kalrez
A2D Y20 0K1	Impact 2-Duo 30 nm OF Kalrez

For More Information

Please call your Regional Customer Service Center today to learn what Entegris can do for you. Visit www.entegris.com and select the "Customer Service" link for the center nearest you.

Terms and Conditions of Sale

All purchases are subject to Entegris' "Terms and Conditions of Sale." To view and print this information, visit Entegris' website at www.entegris.com and select the Legal Notices link from the footer found on the home page.

Entegris®, Mykrolis®, Impact® and Connectology® are registered trademarks of Entegris, Inc. Kalrez® is a registered trademark of DuPont Dow Elastomers.

ENTEGRIS, INC.

Corporate Headquarters | 129 Concord Road | Billerica, MA 01821 USA
 Customer Service Tel. +1 952 556 4181 | Customer Service Fax +1 952 556 8022
 In North America 800 394 4083 | www.entegris.com